



PLATINUM™ SERIES ROOF SYSTEM INSTALLATION MANUAL

Rigid Global Buildings
18933 Aldine Westfield - Houston, TX 77073
www.RigidBuilding.com

TABLE OF CONTENTS

1.0 GENERAL	
1.1 Purpose of the Installation Guide	7.3- 1
1.2 Customer's Responsibility	7.3- 1
2.0 SAFE ROOF INSTALLATION	
2.1 Erector's Responsibility	7.3- 2
2.2 OSHA	7.3- 2
2.3 Walking & Working on Roof Panels	7.3- 2
2.4 Handling Roof Materials in Strong Winds	7.3- 3
3.0 CHECKING THE STRUCTURE	
3.1 Completed and Braced	7.3- 4
3.2 Lateral Stability	7.3- 4
3.3 Alignment	7.3- 4
4.0 RECEIVING & HANDLING ROOF MATERIALS	
4.1 Equipment for Unloading and Lifting	7.3- 5
4.2 Material Inventory	7.3- 5
4.3 Lifting Roof Panel Bundles	7.3- 6
4.4 Field Storage of Roof Materials	7.3- 7
4.5 Handling Individual Roof Panels	
5.0 ROOF INSTALLATION BASICS	
5.1 Proper Tools	7.3- 8
5.2 Equipment List	7.3- 8
5.3 Sealants	7.3- 8
5.4 Fasteners	7.3- 9
5.5 Field Cutting Panels and Flashing	7.3- 10
6.0 ROOF PANEL LAYOUT	
6.1 Sheeting Direction and Modularity	7.3- 11
6.2 Layout & Checking for Coverage	7.3- 11
6.3 Appearance Considerations	7.3- 11
7.0 INSPECTION OF ROOF ASSEMBLY DURING INSTALLATION	
7.1 Importance of Inspection	7.3- 12
7.2 Inspection List	7.3- 12
8.0 STANDARD PARTS	
8.1 General	7.3- 15
8.2 Standard Parts Details	7.3- 15



9.0 ROOF INSTALLATION DETAILS

9.1 General	7.3- 22
9.2 Preparation for Roof Panel Installation	7.3- 23
9.3 Roof Panel Installation	7.3- 33
9.4 Termination Panel Installation	7.3- 57
9.5 Outside Closure Installation	7.3- 63
9.6 Rake Trim Installation	7.3- 72
9.7 Rake Transition Installation	7.3- 77
9.8 Ridge Flashing Installation	7.3- 80
9.9 High Eave Transition Installation	7.3- 86
9.10 Eave Gutter Installation	7.3- 90
9.11 Hip and Valley Installation	7.3- 94

1.0 GENERAL

1.1 Purpose of the Installation Guide

This installation guide is provided to **Rigid Global Buildings** customers and their erectors as the recommended procedure for the correct assembly of the **Platinum Standing Seam Roof System**.

This guide is intended to be used in conjunction with the project's erection drawings to help plan and organize the installation of the **Platinum Standing Seam Roof System**. The erection drawings identify the applicable roof conditions and govern specific part arrangements. The instructions will help you identify parts, establish the installation sequence, demonstrate correct assembly, and point out any areas or procedures requiring special emphasis or attention.

This installation guide applies to the standard **Platinum Standing Seam Roof System**. Custom roof conditions, including custom details and instructions, will be covered by the erection drawings. In case of conflict between this installation guide and the erection drawings, the erection drawings will take precedence.

1.2 Customer's Responsibility

The customer is responsible for proper installation of the roof in accordance with the erection drawings and this installation guide, and in accordance with good engineering and construction practices.

The customer must take the responsibility for selecting a competent erector, insist that the work be performed by qualified and experienced standing seam metal roof installers, insist that the erector take time to study and understand this guide, then assure that the erector correctly follows the guide's instructions.

Rigid Global Buildings does not guarantee and is not liable for the quality of erection. **Rigid Global Buildings** is not responsible for building defects that may be attributed to improper erection or the negligence of other parties.

Clarification concerning the **Rigid Global Buildings** roof installation should be directed to the **Rigid Global Buildings** Customer Service Manager.

Contact the **Rigid Global Buildings** office:

Rigid Global Buildings
18815 Aldine Westfield
Houston, Texas 77073

Phone : (281) 443-9065
Toll Free : (888) 467-4443
Fax : (281) 443-9064

GENERAL

2.0 SAFE ROOF INSTALLATION

2.1 Erector's Responsibility

The erector of the roof system is responsible for the safe execution of this installation guide. These instructions are intended to describe the sequence and proper placement of parts. They are not intended to prescribe comprehensive safety procedures.

If the erector cannot safely assemble the roof in accordance with these instructions, it is the responsibility of the erector to stop the work and contact **Rigid Global Buildings** to determine alternate assembly procedures.

2.2 OSHA

The Occupational Safety and Health Act (OSHA) has promulgated many regulations applicable to the installation of this or any other roof system. These regulations, identified as Part 1926, Safety and Health Regulations for Construction, are available from any government bookstore. The objective of the OSHA standards is to protect the worker from injury or illness. These OSHA regulations should be recognized as job site requirements and be fully complied with.

Failure to do so may result in substantial fines in the event of an OSHA inspection. Safe installation practices may be further defined and made mandatory by state or local ordinances.

Maintaining good housekeeping on the job site is recognized as being important to both OSHA compliance and to successful job completion.

2.3 Walking & Working on Roof Panels

Do not use a roof panel as a working platform. An unsecured panel could collapse under the weight of a person standing between purlins or at the panel end.

Do not walk on the last installed panel run, as the unsecured edge could collapse under a person's weight. When installing clips or making endlap connections, etc., stand where the roof structural will support your weight.

An approved and safe walking platform should be used in high traffic areas to prevent the roof panel from being deformed, scratched, or scuffed.

A. PLACING PANELS ON THE STRUCTURE

Do not place bundles of panels on the roof structure without first verifying the structure will safely support the concentrated weight of the panels and the weight of the installation crew. Some roof structures may not be designed to support the weight of a full panel bundle without additional structure support.

B. WALKING ON ROOF PANELS

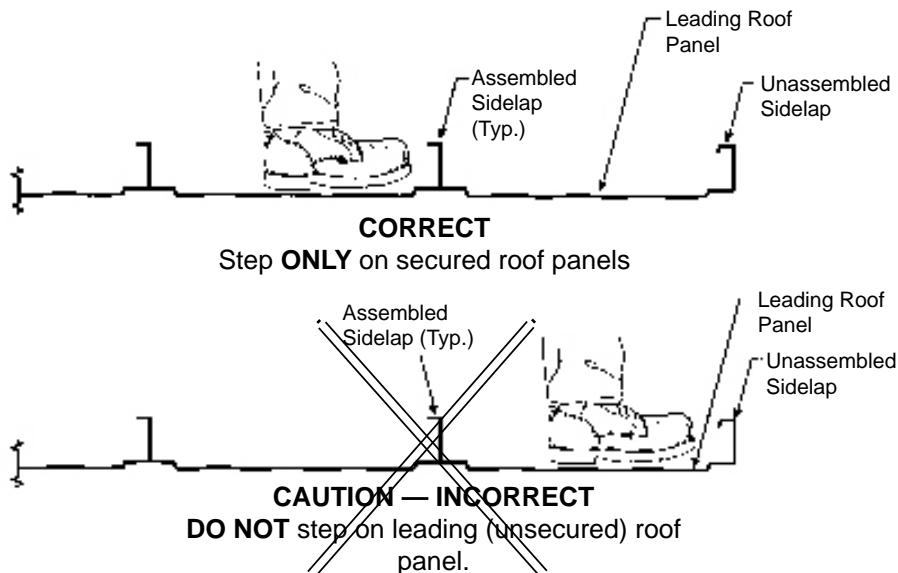

SAFE ROOF INSTALLATION

2.0 SAFE ROOF INSTALLATION

2.3 Walking & Working on Roof Panels (Continued)

C. SAFETY EQUIPMENT

The use of safety equipment for the roof panel installation is recommended at all times during the installation process. However, when using lanyards, ensure that the clasp, belt hooks and wire cables are covered in such a manner that they will not scratch the panel surface if accidentally dragged along the panel.

D. CREW SIZE

The length of the individual roof panels should be considered when determining the crew size. It is recommended that under normal conditions, there be one person for every ten feet of panel length, plus one.

E. PANEL OVERHANG

Do not stand on the end of unsupported (cantilevered) panels at the eave or ridge. Standing on the cantilever portion may result in panel collapse.

F. POINT LOADS

When properly supported by the structurals, panels are designed to support uniform loads, which are evenly distributed over the panel surfaces. Point loads that occur in small or concentrated areas, such as heavy equipment, ladder or platform feet, etc., may cause panel deformation or even panel collapse.

G. SLICK SURFACES

Panel surfaces and structural steel surfaces are hard, smooth, and nonabsorbent, which causes these surfaces to be very slick when wet or covered with snow or ice. Even blowing sand or heavy dust can make these surfaces difficult to walk on without slipping.

Unpainted panel surfaces are often coated with oil to accommodate the panel-fabrication process. Although designed to wash away or evaporate during normal weather, the oil on new panels can be extremely slick, especially during periods of light rain or dew.

Caution must be exercised to prevent slipping and falling onto the roof surface or even sliding off the roof. Non-slip footwear is a necessity and non-slip working platforms are recommended.

H. ELECTRICAL CONDUCTANCE

Metal panels are excellent electrical conductors. A common cause of injury is the contact of metal panels with power lines during handling and installation. The location of all power lines must be noted and, if possible, flagged. The installation process must be routed to avoid accidental contact with all power lines and high voltage services and equipment. All tools and power cords must be properly insulated and grounded and the use of approved ground fault circuit breakers is recommended.

I. FALSE SECURITY OF INSULATION

Blanket and board insulation blocks the installer's view of the ground below the roof. Serious injury can occur when the installer gets a false sense of security because he cannot see the ground and steps through the insulation.

J. SHARP EDGES

Some edges of panels and flashing are razor sharp and can cause severe cuts if proper protective hand gear is not worn. Be careful not to injure others while moving panels and flashing.

2.4. Handling Roof Materials in Strong Winds

Do not attempt to move panels in strong winds. Wind pressure can easily cause a man to lose balance and fall. Strong wind uplift on a panel can lift the weight of the man carrying the panel.

Loose, wind borne panels are very dangerous and can cause severe injury and damage.

Secure stacks of panels with banding or tie-downs, so wind will not blow the panels off the roof. Clamp individual unsecured panels to the roof structurals. Clamp or block panel bundles and accessory crates to prevent them from sliding down the roof slope.

SAFE ROOF INSTALLATION

3.0 CHECKING THE STRUCTURE

3.1 Completed and Braced

Before placing materials and workers on the roof structure to start roof installation, it must be confirmed that the structure is designed to accommodate the material and erection loads as well as the appropriate live loads and wind uplift loads. It also must be determined that the structure is complete

and structurally sound with all structural connections and bracing in place and secure.

3.2 Lateral Stability

The sliding clip method of attaching the roof panels to the roof structurals provides only limited lateral stability and diaphragm bracing to the roof structurals.

Before placing materials on the roof and starting the roof installation, confirm that the necessary roof bracing and sag angles, strapping or bridging is in place and secured.

3.3 Alignment

Prior to installation, roof structurals should be checked for overall dimensions and evenness of plane. The roof structurals should also be checked to verify the roof system can be installed without interference. Also, roof structurals nearest the panel endlaps, ridge or high eave should be checked for correct location to properly accommodate the roof components.

To assure that the accumulation of structure length error and rake straightness error does not exceed the roof system's tolerance, the structure length should be measured from rake line to rake line at each eave, at the ridge and at each point where there is a significant error or change in rake straightness (this usually occurs at an end rafter splice).

A. TOLERANCES

To assure the roof system's correct fit-up and designed weather tightness, the structure must be aligned within the following tolerances:

Out of Square — The roof system can accommodate 1/8" of sawtooth of the roof panel ends at the eave, ridge and panel splices. This means the allowable out of square of the rake line relative to the eave line and ridge line is 1/2" for each 10' of rake run.

Structure Width and Eave Straightness — The roof system is designed to accommodate $\pm 2"$ of overall structure width error, or $\pm 1"$ of eave straightness error at each eave.

To assure that the accumulation of the structure width error and eave straightness error does not exceed the roof system's tolerance, the structure width should be measured from eave line to eave line at each rake, at the first frame line from each rake and at each point where there is a significant error or change in eave straightness (this usually occurs at a frame line or at a wind column).

Structure Length and Rake Straightness — The roof system is designed to accommodate $\pm 2"$ of overall structure length error, or $\pm 1"$ of rake straightness error at each rake.

B. MEASURING

Structure length and width may be measured with a steel measuring tape from the face of the eave or rake member to the face of the opposite eave or rake member. The measuring tape must be parallel to the relative eave or rake line and must be stretched taut.

Eave and rake straightness may be determined by measuring deviations from a string line, which is stretched taut along the eave or rake line.

C. AESTHETIC ACCEPTANCE

Although these structure alignment tolerances will allow for reasonable roof component fit-up and ease of installation, the extremes of these tolerances may be aesthetically objectionable and should be confirmed with the customer before starting the roof installation.

D. CORRECTIONS

Any structure alignment error, which exceeds the above stated tolerances, must be corrected before roof installation can begin. If it is decided that the structure alignment errors cannot be corrected, alternate roof details may have to be developed. The alternate details may require additional materials, modified parts (with additional cost, fabrication and delivery time) and additional installation time. **Rigid Global Buildings** cannot assure the performance of such alternate details.

CHECKING THE STRUCTURE

4.0 RECEIVING & HANDLING ROOF MATERIALS

4.1 Material Inventory

Your material is carefully inspected and crated before leaving the plant and accepted by the transportation company as being complete and in satisfactory condition. It is the carrier's responsibility to deliver the shipment intact. It is the consignee's responsibility to inspect the shipment for damages and shortages when it is delivered.

Conducting a material inventory at the time of delivery is essential. By conducting the materials inventory, the erector is able to identify any material shortage or damage and avoid stopping installation later because of such shortage or damage.

It is imperative that any shortages or damage of the delivered materials be noted at once and clearly marked on the bill of lading before signature of acceptance. Notify **Rigid Global Buildings** immediately of any conflicts. **Rigid Global Buildings** will not be responsible for shortages or damages unless they are noted on the bill of lading.

In the case of packaged components (such as clips, fasteners and sealants, etc.), the quantities are marked on their container and should be checked against the bill of materials. **Rigid Global Buildings must be notified of any shortages or concealed damage within 5 days of delivery.**

4.2 Equipment For Unloading and Lifting

Hoisting equipment is necessary to unload and position the panels and accessory crates for site storage and installation. The equipment must have sufficient capacity and reach to place the material where it is required for efficient installation.

Slings will be required to minimize panel damage. The recommended slings are nylon straps of 6" minimum width and of sufficient length to accommodate the panel bundle girth. A spreader bar will be required for the longer panel crates

to assure correct sling spacing and uniform lifting. The spreader bar must be large enough to handle the maximum panel bundle weight and length.

A forklift is handy for unloading and placing shorter panel and accessory crates.

4.3 Lifting Roof Panel Bundles

Under normal conditions, panel crates less than 35' long can be lifted with two slings spaced at third points. Panel crates longer than 35' can be lifted with three slings located at quarter points using a spreader bar to achieve correct sling spacing for uniform lift.

necessary to control the load during lifting, especially if operating in the wind.

Panel crates less than 25' long may be lifted with a forklift only if the forks are spread at least 5' apart and blocking is used to prevent panel damage by the forks.

Slings should be located under the cross boards. Loads should always be checked for secure hook-up, proper balance, and lift clearance. Tag lines should be used if

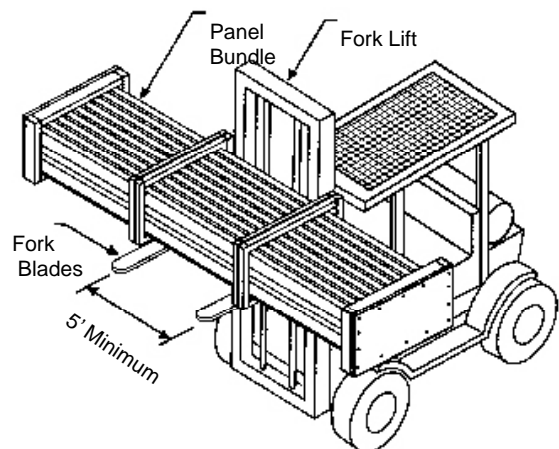
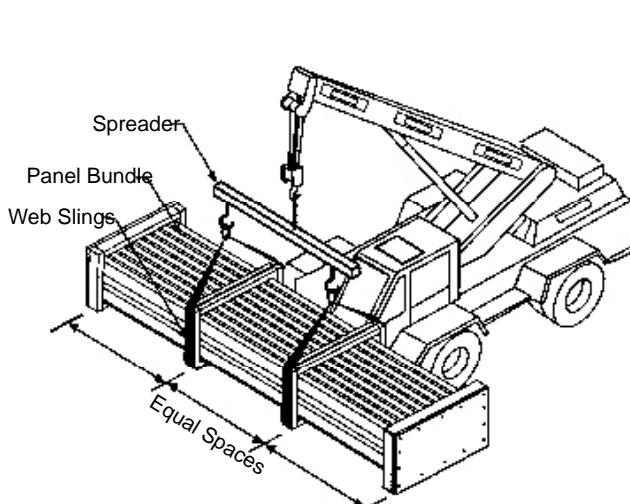

RECEIVING AND HANDLING ROOF MATERIALS

4.0 RECEIVING & HANDLING ROOF MATERIALS

4.4 Field Storage of Roof Materials

Upon acceptance of the shipment, the customer or his representative is responsible for proper handling storage and security of the roof materials. *Rigid Global Buildings* is not liable for damage or loss of materials at the job site.

The roof panel bundles should be stored on the job site in accordance with the following recommendations:

- a. Store panels in a protected area, out of standing water and drifting snow, etc.
- b. Elevate panels with blocking to allow air circulation under the bundle.
- c. Slope panels for drainage of moisture from the panels.
- d. As necessary, cover panels with waterproof tarp, allowing for air circulation (do not wrap tarp under panel crate or restrict air movement).
- e. Inspect panels daily for moisture accumulation.

f. If panel bundles contain moisture, the panels should be dried and re-stacked. Use care in re-stacking to avoid damage to panels.

g. Opened or re-stacked panel bundles should be secured to prevent wind damage.

When moving panel bundles, extreme caution should be taken to prevent damage to the panel edges. Uncrated panels should be supported at each end and at 10' spaces.

All bundles or loose panels on the roof should be banded to the roof structurals at the end of each workday. On steep roofs, provisions should be taken to prevent panels and panel crates from sliding off the roof. Be sure to set panel bundles on the roof in the proper direction for the installation sequence.

Trim and accessories should be stored in a secure area and protected from damage, weather, and theft. Fasteners, sealants, closures, etc. should be stored out of the weather and protected from contamination.

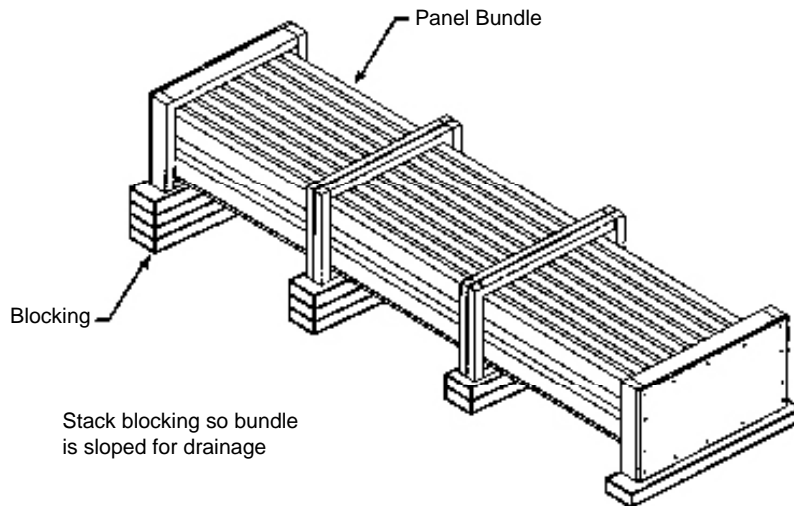

RECEIVING AND HANDLING ROOF MATERIALS

4.0 RECEIVING & HANDLING ROOF MATERIALS

4.5 Handling Individual Roof Panels

To lift individual panels, lift one side of the panel by the seam letting it hang naturally to prevent buckling. Pick-up points should not be more than 10' apart. Do not pick-up panels by the ends only, or in a flat position.

If the individual panels are to be lifted to the roof by hand line, the common method is to use the vice grip "C" clamps. Position the clamps on the flat of the panel, as close as possible to one edge so the panel is lifted in a vertical position.

The jaws of the vice grips must be padded to prevent damage to the panel surface. The clamps should be uniformly spaced, no more than 10' apart and the hand lines must be pulled in unison so that uneven lifting does not buckle the panel. Be sure the clamps are tight on the panel and the line is secure to prevent dropping the panel, which can result in personal injury and property damage.

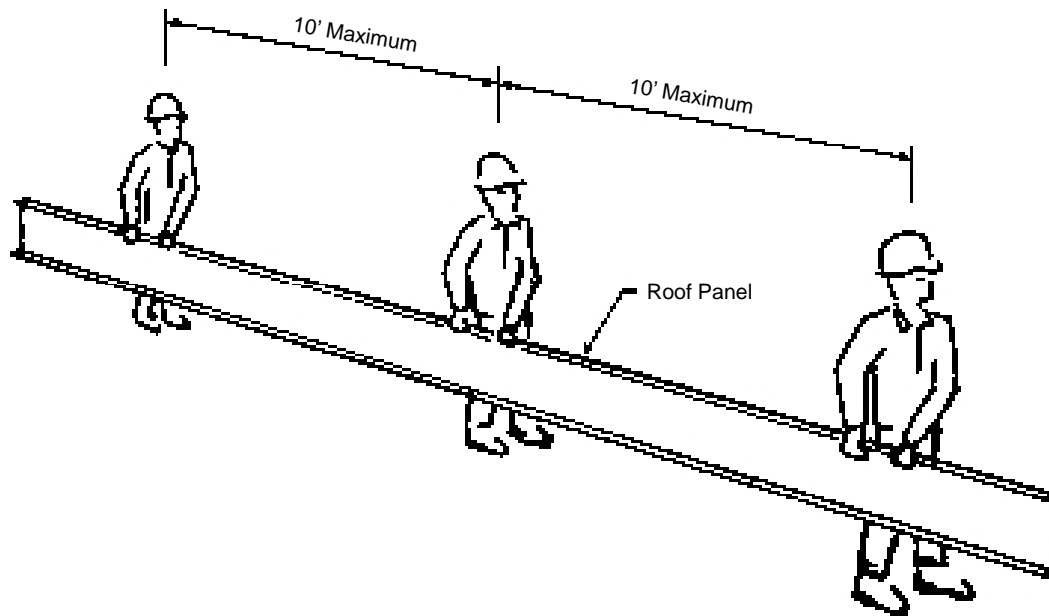

RECEIVING AND HANDLING ROOF MATERIALS



5.0 ROOF INSTALLATION BASICS

5.1 Proper Tools

Before starting paneling, be sure that the proper equipment and tools are on hand. The tools must be in good operating condition and operators should adhere to safety precautions at all times.

Improperly operating tools, too few tools, inadequate power source, or other equipment deficiencies slow down the installation process. The cost of inefficient working is usually greater than the cost of providing good equipment.

5.2 Equipment List

The following tools and equipment should be considered for efficient installation of the *Platinum standing seam roof*. Actual tools and equipment required may vary due to variations in building type and construction.

This list should not be interpreted as a limitation to your inventory of installation equipment.

PT Motorized Seaming Machine with Grease Gun
*ESE #812 Hand Seamer
Screw Guns — Designed for use with self-drilling screws
Socket Extensions — 6" extension for screw gun
Hex Socket Heads — 5/16" and 3/8", magnetic
Drill Motor — 1/4" capacity
Drill Bits — Assortment
Sheet Metal Cutter — or power shears or nibbler
"C" Clamps — vise grip, sheet metal, type
Pop Rivet Tool — 1/8" capacity
Sheet Metal Shears — left and right cut
Steel Measuring Tape — 12', 50', 100'
Nylon String Line

Chalk Line
Brooms
Marking Pen
Caulk Guns — for 1/10 gallon sealant tubes
Power Source and Extension Cords — capable of handling the total equipment requirements, including 20-amp seamer machine, without power drop due to extension cord length.

*These tools are specifically designed for the *Platinum Roof Panel* and are available from the *Rigid Global Buildings*

5.3 Sealants

A. TEMPERATURE EFFECTS

Temperature extremes must be considered during installation of the roof due to the sensitivity of sealants. The recommended installation temperature range is 20° F to 120° F. At colder temperatures, the sealant stiffens resulting in loss of adhesion and compressibility. At hotter temperatures, the sealant becomes too soft for practical handling. On cold but sunny days, the panel's surface may become warm enough to accept the application of a heated sealant even though the air temperature is below 20° F.

When overnight temperatures fall below freezing, the sealant should be stored in a heated room so it will be warm enough to use the following day. On hot days, the sealant cartons should be stored off the roof in a cool and shaded area. While on the roof, sealant rolls should be kept shaded until actual use.

In very cold weather, it is recommended that the fasteners be tightened slowly and only tight enough that the sealant is in full contact with the panel or flashing. Then on the next sunny day, complete the tightening process after the sun warms the panel and flashing surfaces.

B. CONTAMINATION

To assure proper adhesion and sealing, the sealant must have complete contact with adjoining surfaces. Contaminants such as water, oil, dirt and dust prevent such contact. The panel and flashing surfaces must be dry and thoroughly cleaned of all contaminants. Before applying tape sealant, the sealant should be checked for contaminants. If the sealant surfaces are contaminated, it must not be used.

During cool weather, condensation or light mist can accumulate on the panel and flashing surface and not be easily noticed. It is recommended that sealants always be kept under protective cover and that the panel and flashing surfaces be wiped dry immediately before installation.

Tape sealant is provided with a protective paper to reduce contamination. Incomplete removal of the protective paper will prevent the sealant's adhesion to the panel or flashing surfaces. Always check that the protective paper is completely removed. Do not remove the protective paper until immediately before the panel or flashing is installed over the sealant.

ROOF INSTALLATION BASICS

5.0 ROOF INSTALLATION BASICS

5.3 Sealants (Continued)

C. COMPRESSION

To assure proper adhesion and seal, the tape sealant must be compressed between the panel and flashing surfaces with firm and uniform pressure. In most cases, the required pressure is applied by the clamping action of screws pulling the adjoining surfaces together. However, the tape sealant's resistance to pressure becomes greater in cold weather.

During cold weather, the fasteners must be tightened slowly to allow the sealant time to compress. If the fasteners are tightened too fast, the fastener may strip out before the sealant compresses adequately, or the panel or flash may deform in the immediate area of the fastener, leaving the rest of the sealant insufficiently compressed.

D. INSIDE CORNERS

An inside radius, such as where the panel flat meets a rib, is usually the most critical area to seal. A common mistake for the installer, is to bridge the sealant across the inside radius. When the lapping panel or flashing is pushed into place, the bridged sealant is stretched and thinned. The sealant may then be too thin to adequately seal this critical area.

When tape sealant is applied at an inside radius, it is recommended that the sealant be folded back on itself, then push the sealant fold into the radius.

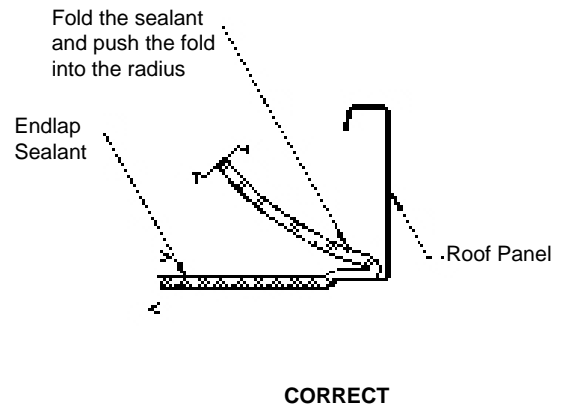
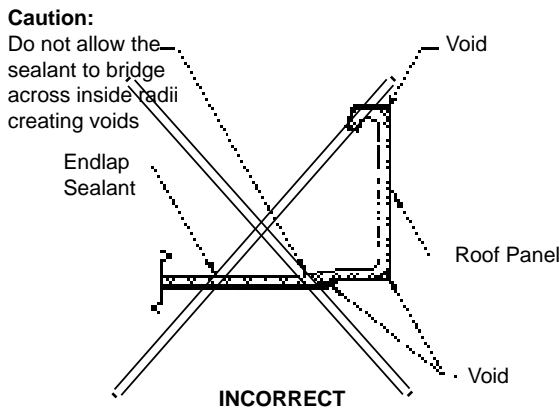

5.4 Fasteners

A. SCREW GUN

Use torque control screw guns for driving self-drilling screws. 2000-2500 RPM screw gun speeds are necessary to attain efficient drilling speeds. High tool amperage (4 to 7 AMP) is required to achieve the proper torque for secure fastening.

B. SOCKETS

Use good quality sockets. Good fitting sockets reduce wobble and stripping of the screw heads, especially the alloy and capped heads. They also minimize objectionable paint chipping and scuffing on colored screws and minimize damage to the protective coating on unpainted screws.

Magnetic sockets collect drill shavings, which will build up and eventually prevent the socket from seating properly on the screw heads. One method of removing the drill shavings is to roll up a ball of tape sealant and push the socket into the sealant.

When the socket is removed from the sealant, most of the drill shavings will remain embedded in the sealant thereby cleaning the socket. This process should be repeated as often as needed to keep the socket clear of drill shavings.

C. SOCKET EXTENSION

A 4" or 6" socket extension is recommended for installing the panel clip screws. With the extension, the screw can be driven straight down without tilting the screw gun to clear the panel or clip. Since socket extensions are slow to wear out, it is usually more cost effective to purchase socket extensions and good quality sockets rather than purchase sockets with built-in extensions.

D. INSTALLATION

Before starting the screw, the materials to be joined must be pressed together with foot or hand pressure. The pressure must be maintained until the screw has drilled through all the materials and the threads have engaged.

ROOF INSTALLATION BASICS



5.0 ROOF INSTALLATION BASICS

5.4 Fasteners (Continued)

Most self-drilling screws require 20 pounds of pressure to maintain the drilling action and to start the thread cutting action. Also, applying such pressure before starting the screw gun will usually prevent tip walking or wandering.

If too little pressure is applied, the drill point may not cut into the metal and the point will heat up and become dull. If the pressure is too heavy, the bottom material may be deflected away, causing a standoff condition, or the drill tip may be broken or split.

Screws must be held perpendicular to the panel or flashing surface during starting and driving.

For proper seating of the fastener-sealing washer, the panel or flashing surface must be clean and drill shavings must be removed from under washers before seating. The fastener must be driven perpendicular to the panel surface so that the washer can seat level without warping or cupping.

Do not over drive screws. Over driving can strip the threads and/or damage the sealing washer. Use screw gun with torque control set to function properly for the combination of fastener size, hole size and material thickness.

The fastener should be driven tight enough to uniformly compress the washer but not so tight that the washer splits or rolls out from under its metal dome. The recommended procedure is to tighten the fastener until the sealing washer just starts to visually bulge from under the metal dome.

As a good installation practice, all roof installers should carry approved oversized screws. Upon stripping or breaking a screw, the screw must be immediately removed and replaced with the appropriate oversized screw. Do not defer the screw replacement to be remembered and fixed later, or to be found by the clean-up crew. The majority of such screws will be overlooked until the customer complains of leakage.

5.5 Field Cutting Panels and Flashing

A. ABRASIVE SAW PROBLEMS

Abrasive saws (circular saws with friction disks) are not recommended for cutting roof panels or flashing. Abrasive saws create high heat that may burn away the protective cladding from the panel edge, causing the edge to rust.

Also, abrasive saw dust contains fine, hot steel particles, which accumulate on panel and flashing surfaces where they rust and can cause staining and rusting of those surfaces.

Rust caused by abrasive saw damage or abrasive dust particles may be excluded from warranty claims.

B. SHEARING METHODS

It is recommended that panels and flashing be cut with shears to provide a clean, undamaged cut. On shear cut edges, the protective cladding extends to the edge of the cut and is often wiped over the edge to further protect the base metal.

Whenever possible, fit the material so that the factory cut edge is exposed and the field cut edge is covered.

When field cutting complex shapes, it is usually easier to cut out a 1" wide strip using both left and right hand shears. The 1" cutout provides clearance to smoothly cut the flats and the clearance to work the shears around tight corners.

When making repetitive cuts (such as cutting panels at a hip condition) it is recommended that a template be made from a piece of drop-off panel or flash to provide fast and accurate marking of the field cut. When using panel material for the template, cut off the top portion of the panel ribs so that the template is easily laid onto the panel being marked.

C. MARKING PANELS

Avoid marking the panels for cutting, etc., in a manner that will leave visible markings and stains, etc., on the finished roof surface. Use chalk or felt tip ink markers. **Do not use graphite (lead) pencils on unpainted panel surfaces, the graphite can cause rusting of the surface.**

ROOF INSTALLATION BASICS

6.0 ROOF PANEL LAYOUT

6.1 Sheeting Direction and Modularity

for maintaining panel modularity. By maintaining panel modularity, proper roof coverage can be obtained and the standard perimeter parts will fit properly without necessity of field modifications or reordering of parts, etc.

For proper fit-up between the panel, sealant and closures or endlap parts, the panels must be held to the width dimension of the panel, as designated on the erection drawings, within a 1/16" width tolerance per panel. The accumulated coverage (start panel to finish panel) tolerance is determined by the ability to keep the panels parallel and to correctly fit and assemble the finish rake condition.

If the roof has conditions such as fixed location penetrations, parapets, fire walls, etc., the accumulated panel coverage may require tighter tolerances for proper fit-up and weather tightness of the roof system.

Recommended for all roofs, but a must for large or complex roofs, is to make a layout of the actual structure (field measured as described in section 3.3) so that the roof panel start and stop dimensions can be laid out to accommodate any structural misalignments.

When the optimal start and finish dimensions are determined, a string line should be set to precisely locate the leading edge of the start panel. After the start panel is secured and engaged with the next panel, the start panel seam will be the reference line for checking accumulated panel coverage.

Platinum roof system is designed to be installed left to right only. Always check the "Sheeting Layout Plan" for details.

Panels with factory swagged ends must be installed with the swag at the downslope end.

The recommended installation sequence is to complete each panel run from eave to ridge before starting the next panel run. This sequence will help ensure straight runs and allow the insulation to be installed immediately ahead of each panel run.

During installation of the roof, considerations must be made

6.2 Layout & Checking for Coverage

Panel coverage is always checked at the eave, ridge, and end splices so that non-parallel seam (or dogleg) conditions can be detected and corrected before they become objectionable. The coverage check should be done with a measuring tape held taut and measured to the same side of the seam and always parallel to the eave to prevent any measuring error.

Every four to six panel runs should be checked for panel modularity. This will assure that the panels are maintaining a straight line and proper coverage is being maintained. If the panels are off module, they should be corrected by equal adjustments of the next four to six panel runs.

6.3 Appearance Considerations

Although the above stated coverage tolerance will provide for reasonable ease of installation and water tightness, such visible conditions as non-parallel panel seams, dogleg of the panel seam at the end splices, non-parallel finish panel

width, and mismatch of panel seams across the ridge, may be objectionable and should be confirmed with the customer before continuing roof installation.

ROOF PANEL LAYOUT

7.0 INSPECTION OF ROOF ASSEMBLY DURING INSTALLATION

7.1 Importance of Inspection

During the roof installation, all areas of the roof system assembly must be frequently inspected to ensure the correct assembly in accordance with the erection drawings and this installation guide.

Failure to assemble the roof system correctly will result in roof performance problems that may require costly corrective work, roof replacement and performance and damage claims etc. Also, incorrect installation may void any or all warranties.

7.2 Inspection List

A. ERECTION DRAWINGS

Check that the erection drawings are available at the job site and have been reviewed for difference with the actual job conditions and differences with the installation guide. Also, confirm that the drawings are the latest issue with the latest revisions and additions.

B. ROOF LAYOUTS

Check that the roof start and finish dimensions have been correctly determined, based on the erection drawings and the actual structural conditions.

C. BEFORE INSTALLING ROOF PANELS

Check that the structural misalignments were corrected in accordance with Section 3.0 of this installation guide.

Check that the correct eave and rake plates and eave trim are in place before installing the roof panels.

Check that the roof panel elevation provided by the panel clip height and insulation system matches the eave and rake plate elevation.

D. PANEL LENGTH

Check that the installed roof panels have the correct overhang at the eave and endlaps and have the correct hold back at the ridge or high eave, in accordance with the erection drawing.

E. EAVE SEAL

Check that the eave sealant is in the correct position on top of the eave trim and that the eave pigtail sealant are correctly placed. Check that the eave fasteners penetrate the center of the eave sealant and into the eave plate. Check that the fasteners are not loose or stripped.

Check that the eave sealant is in complete contact with the roof panel and eave trim without any voids or gaps. Confirm that the roof panel and eave trim are clean and dry during installation and that the sealant is not wet or otherwise contaminated.

F. ENDLAP SEAL

Check that the roof panel endlaps are correctly assembled and that the lapping panels are tightly nested without visible gaps.

Check that the sealant is in the correct position and is in complete contact with the lapped panels without any voids or gaps, especially at the radius between the panel flat and the vertical legs of the panel. Confirm that the panels are clean and dry during installation and that the sealant is not wet or otherwise contaminated.

Check that the pigtail sealant is in the correct position and seals the endlap seam notches.

Check that the endlap fasteners penetrate through the center of the sealant and into the back-up channel. Check that the fasteners are not loose or stripped.

Check that the panel surfaces above and below the endlap are not bowed down, causing water ponding and debris accumulations.

G. RIDGE SEAL

Check that the outside closure assembly is correctly assembled.

Check that the sealant is in the correct position and is in complete contact with the outside closure and the roof panel without any voids or gaps. Confirm that the outside closure and roof panels are clean and dry during installation and the sealant is not wet or contaminated.

Check that the outside closure fasteners penetrate through the center of the sealant and into the back-up channel. Check that the fasteners are not loose or stripped.

Check that the tube sealant is installed along the back of the outside closure as necessary to seal any voids around the panel seam area.

INSPECTION OF ROOF ASSEMBLY

7.0 INSPECTION OF ROOF ASSEMBLY DURING INSTALLATION

7.2 Inspection List (Continued)

H. RAKE SEAL

Check that the termination zee is correctly assembled with the splices correctly oriented for downhill watershed.

If there are roof panel endlaps, check that the endlap sealant contacts the termination zee sealant or that a pigtail sealant is applied for that purpose.

Check that the sealant is in the correct position above and below the roof panel.

Check that the termination zee sets fully on the sealant and that the sealant is in complete contact with the roof panel and the zee without any voids or gaps. Confirm that the roof panel and zee are clean and dry during installation and that the sealant was not wet or contaminated.

Check that the termination zee fasteners penetrate the center of the sealant and into the rake plate. Check that the fasteners are not loose or stripped.

I. PANEL CLIP ATTACHMENT

Check that the panel clips are correctly and tightly fitted to the panel without any distortion or damage of the clip tab. On sliding clips, check that the clip tab is centered on the clip base between the centering tabs.

Check that the clips are located along each panel sidelap at each roof structural or at the locations specified on the erection drawings.

Check that the panel clip fasteners are of the type, size, length, finish and quantity-per-clip as specified on the erection drawings.

Check that the panel clip fasteners are not loose or stripped. In the case of multi-layered construction, verify that the fasteners penetrated and engaged the specified structural member.

J. SIDELAP

Check that the factory installed sidelap sealant is in the correct position without voids or interruptions and is not damaged, wet or otherwise contaminated.

Check that the full length of each sidelap seam is correctly seamed.

Check that the panel coverage tolerance does not exceed

1/16" per panel and that the accumulated coverage will allow proper fit and assembly of the end dams and finish rake condition and any other critical fit conditions such as penetrations, parapets, etc.

K. FLASHING AND PENETRATIONS

Check that all flashing (including penetrations) are correctly assembled and tightly fitted. Check that the required sealants are correctly positioned and in complete contact with the adjoining surfaces without voids or interruptions. Confirm that the sealants and adjoining surfaces are clean and dry during installation.

Check that the flashing splices are correctly lapped, sealed and fastened.

Check that the flashing is sufficiently pitched to shed water and eliminate ponding areas, especially at the critical splices, endlaps and corners.

Check that the fasteners are of the specified type, size, length, finish and spacing. Check that the fasteners are not loose or stripped. Check that the sealing washers are in full contact with the flashing surface and not distorted, split or otherwise damaged.

Along the rakes, high eave transitions, fixed penetrations, etc., check that the flashing is not constrained and will allow for the roof's expansion/contraction movement.

L. SURFACE CONDITIONS

Damaged roof system surfaces are subject to corrosion and performance problems and may void the material and performance warranties.

Check that the panel and flashing surfaces are not being subjected to abusive conditions such as: careless handling of panels and flashing, excessive roof traffic, abrasive or contaminated footwear, rough handling of materials, tools and equipment, or contact with abrasive materials or residue, etc.

Check that the panel and flashing surfaces are not being subjected to exposed metal objects and materials left on the roof such as: tools, material drop-off, fasteners, wire, staples, drill and nibbler chips, saw and file particles, metal shaving, etc. In the process of rusting, these materials will absorb the panel's protective coating, thus leaving the panels exposed to rusting.

INSPECTION OF ROOF ASSEMBLY

7.0 INSPECTION OF ROOF ASSEMBLY DURING INSTALLATION

7.2 Inspection List (Continued)

Check that the panels and flashing are not being subjected to long term wet conditions such as: standing water, consistent sources of steam, mist, spray, dripping or runoff, wet debris, wet insulation or other moisture holding material.

Check that the panels and flashing are not subjected to direct contact or runoff from corrosive materials such as: copper pipes and flashing, uncured cement, treated lumber anti-icing chemicals, strong solvents or other corrosive materials.

Check that graphite pencils were not used to mark on unpainted surfaces. The graphite marks can cause rusting.

Check that the roof materials are not subjected to damaging heat such as: cutting torches, abrasive saws, etc.

M. UNSPECIFIED MATERIALS

Use of the wrong materials may cause installation and performance problems and may void the performance and material warranties.

Check that all installed roof system materials, especially sealants and fasteners, are only those which are provided or specified by *Rigid Global Buildings* for your specific project and are used only as specified on the erection drawings and this installation guide.

Rigid Global Buildings cannot be responsible for the performance of roof materials that are not provided, specified or approved by *Rigid Global Buildings*.

INSPECTION OF ROOF ASSEMBLY

8.0 STANDARD PARTS

8.1 General

The following details provide a basic description and graphic illustrations of the standard roof assembly parts. The purpose of these details is to assist the erector in the correct selection and identification of parts.

Because of the many variations in conditions, it is important that you review the job conditions to identify the specific parts required for your job.

Review the erection drawings for any special parts or parts which are different from the standard parts shown in these details. If differences exist, the erection drawings will have preference.

For proper fit-up, sealing and fastening, and to help ensure the roof assembly's weathertightness, structural capability, durability and appearance, the correct parts must be used. Do not use parts other than those specified on the erection drawings.

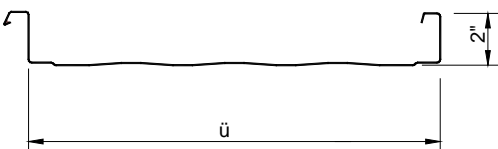
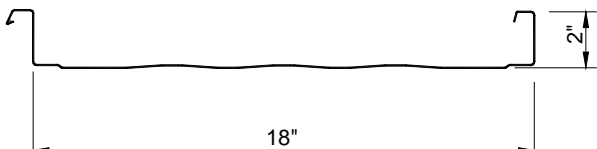
<p>216 ROOF PANEL (16" wide panel)</p> <ul style="list-style-type: none"> • 22 or 24 gauge Steel • Painted or Galvalume Finish • Flat or striated • Factory notched for endlap • Factory swag (optional)  <p>PC-216 (Specify gauge, finish, pan pattern & length)</p>	<p>218 ROOF PANEL (18" wide panel)</p> <ul style="list-style-type: none"> • 22 or 24 gauge Steel • Painted or Galvalume Finish • Flat or striated • Factory notched for endlap • Factory swag (optional)  <p>PC-218 (Specify gauge, finish, pan pattern & length)</p>
---	--

*****To comply with UL 90 construction, the purlin spacing should not exceed 5'-0" o.c. along the roof slope.**

8.2 ROOF PANELS

8.0 STANDARD PARTS

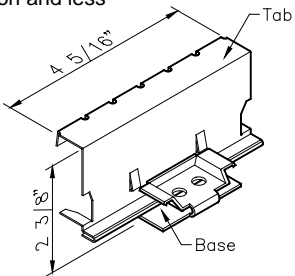
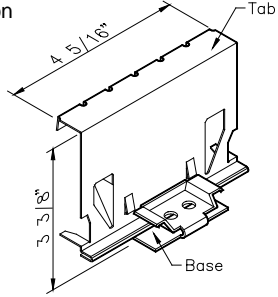
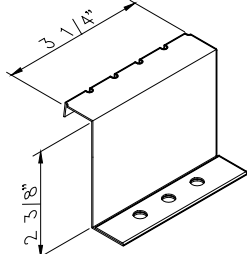
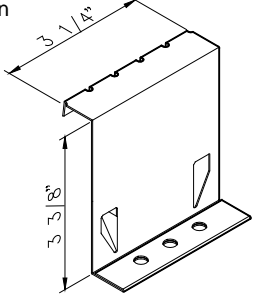
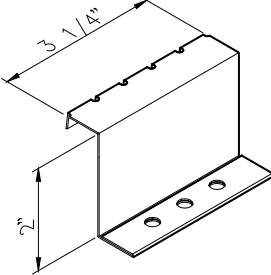
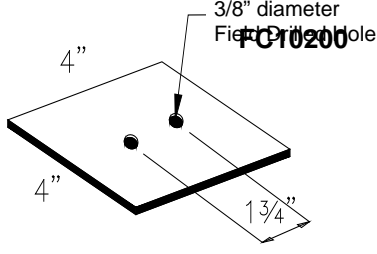
<p>LOW FLOATING CLIP (for 3/8" stand-off)</p> <ul style="list-style-type: none"> • 20 ga. Galvanized Steel, Tab • 16 ga. Galvanized Steel, Base • For use with 3" insulation and less  <p>MC1203</p>	<p>HIGH FLOATING CLIP (for 1 3/8" stand-off)</p> <ul style="list-style-type: none"> • 20 ga. Galvanized Steel, Tab • 16 ga. Galvanized Steel, Base • For use with up to 6" insulation • For Roof Panel runs greater than 200'  <p>MC1213</p>
<p>LOW FIXED CLIP (for 3/8" stand-off)</p> <ul style="list-style-type: none"> • 20 ga. Galvanized Steel • For use with 3" insulation and less • For Roof Panel runs 200' and less  <p>FC10203</p>	<p>HIGH FIXED CLIP (for 1 3/8" stand-off)</p> <ul style="list-style-type: none"> • 20 ga. Galvanized Steel • For use with up to 6" insulation • For Roof Panel runs greater than 200'  <p>FC10213</p>
<p>UTILITY CLIP (for 0" stand-off)</p> <ul style="list-style-type: none"> • 20 ga. Galvanized Steel • For use with 8" insulation or deck by others  <p>FC10200</p>	<p>BEARING PLATE</p> <ul style="list-style-type: none"> • 16 ga. Red Oxide • Required on Plywood or Rigid Board Insulation  <p>BP-20</p>

8.3 PANEL CLIPS & BEARING PLATE

8.0 STANDARD PARTS

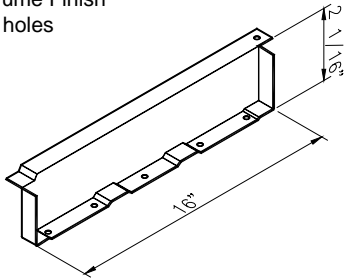
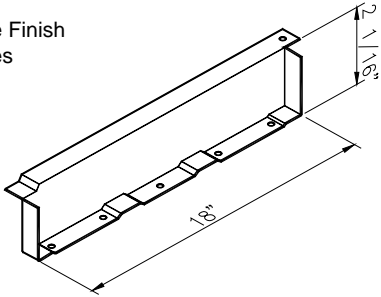
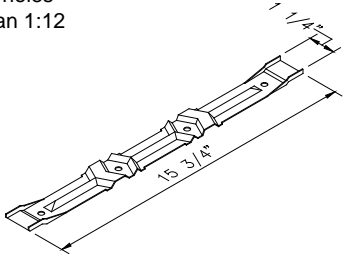
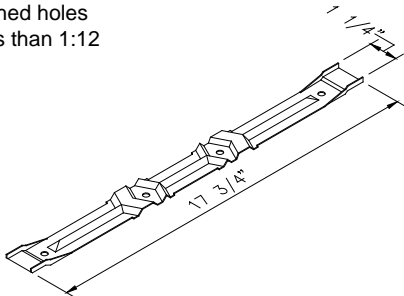
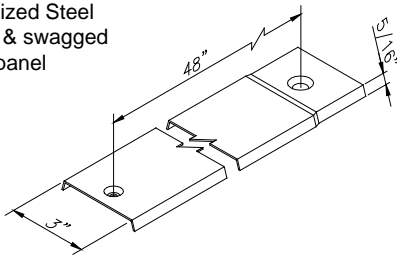
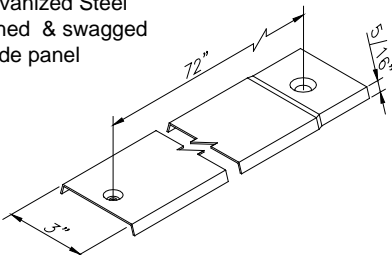
<p>OUTSIDE CLOSURE (for 16" wide panel)</p> <ul style="list-style-type: none"> • 24 gauge Steel • Painted or Galvalume Finish • Factory punched holes  <p>FED216 (Specify finish)</p>	<p>OUTSIDE CLOSURE (for 18" wide panel)</p> <ul style="list-style-type: none"> • 24 gauge Steel • Painted or Galvalume Finish • Factory punched holes  <p>FED218 (Specify finish)</p>
<p>CINCH STRAP (for 16" wide panel)</p> <ul style="list-style-type: none"> • 18 gauge Stainless Steel Only • Factory punched holes • For slope less than 1:12  <p>CS116</p>	<p>CINCH STRAP (for 18" wide panel)</p> <ul style="list-style-type: none"> • 18 gauge Stainless Steel Only • Factory punched holes • For slope less than 1:12  <p>CS118</p>
<p>BACK-UP CHANNEL (for 48" wide insulation)</p> <ul style="list-style-type: none"> • 16 gauge Galvanized Steel • Factory punched & swagged • For (3) 16" wide panel  <p>BP148</p>	<p>BACK-UP CHANNEL (for 72" wide insulation)</p> <ul style="list-style-type: none"> • 16 gauge Galvanized Steel • Factory punched & swagged • For (4) 18" wide panel  <p>BP172</p>

8.4 CLOSURES, ENDLAPS & TERMINATION PARTS

8.0 STANDARD PARTS

LOW FLOATING EAVE PLATE

- 14 gauge, Red Oxide
- 8'-0" length
- Factory punched slots

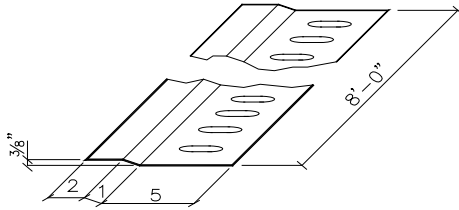

HW-7601

HIGH FLOATING EAVE PLATE

- 14 gauge, Red Oxide
- 8'-0" length
- Factory punched slots

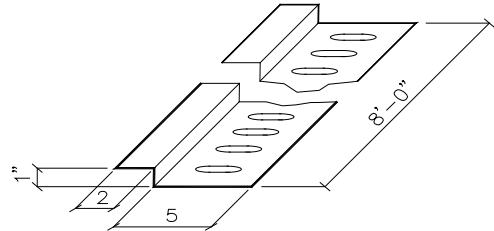

HW-7611

LOW FLOATING RAKE PLATE

- (for 3/8" stand-off)
- 14 gauge Red Oxide
- 10'-0" length
- Factory punched slots

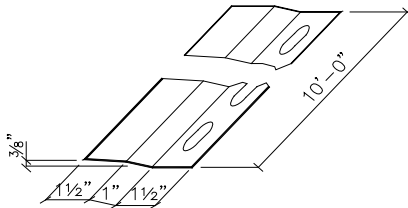

RP038

HIGH FLOATING RAKE PLATE

HIGH FIXED EAVE PLATE

- (for 1 3/8" stand-off)
- 14 gauge Red Oxide
- 10'-0" length
- Factory punched slots

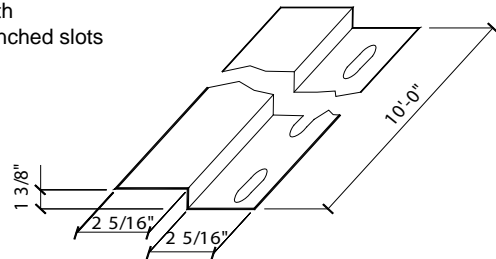

RP138

LOW RAKE SUPPORT

- 14 gauge, Red Oxide
- 10'-0" length
- Factory punched slots

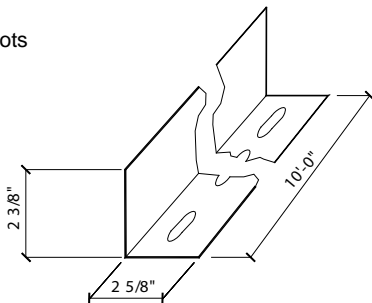

RS238

HIGH RAKE SUPPORT

- 14 gauge, Red Oxide
- 10'-0" length
- Factory punched slots

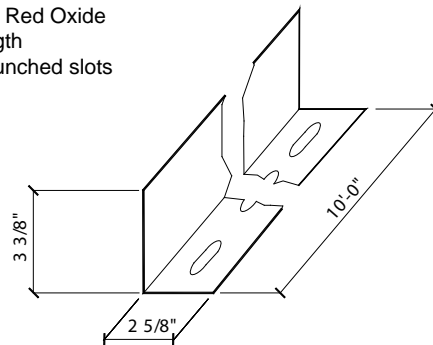

RS038P

8.5 EAVE & RAKE PLATES

8.0 STANDARD PARTS

THERMAL BLOCK

- Extruded Polystyrene Foam
- 3/8", 5/8", or 1" Thick

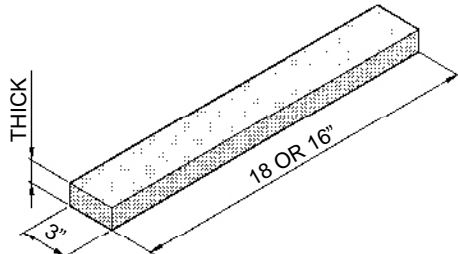

TBS218
TBS216__ (Specify thickness)

THERMAL BLOCKS SELECTION CHART

	LOW SYSTEM	HIGH SYSTEM
No Insulation	3/8" Thermal Blocks	N/A
3" Insulation	N/A	1" Thermal Blocks
4" Insulation	N/A	5/8" Thermal Blocks
6" Insulation	N/A	3/8" Thermal Blocks

VALLEY SEALANT

- 3/16" x 2 1/2" profiled Butyl Tape Sealant
- 20' roll

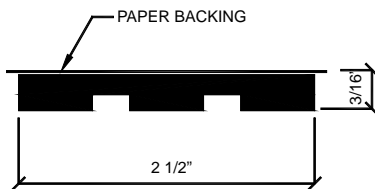

TBS01

FLASHING SEALANT

- (for flashing laps & joints)
- 3/16" x 7/8" Butyl Tape Sealant
 - 25' Roll

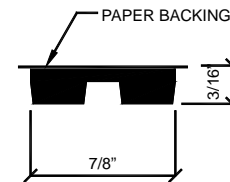

DBS00

EAVE & ENDLAP SEALANT

- (refer to manual for application)
- 3/16" x 7/8" profiled Butyl Tape Sealant
 - 25' roll

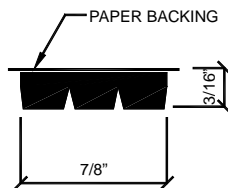

TBS02

TUBE SEALANT



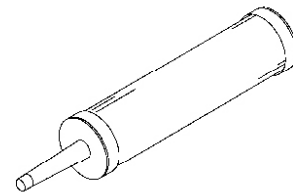



- Poly-Urethane Gun Grade Sealant available in White, M. Bronze, Almond and Gray
- Silicone Sealant available in Clear Color
- 1/10 Gal. Tubes

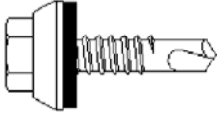

TSLP__ (Specify Color)

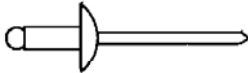
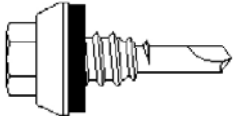

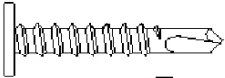
8.6 SEALANT & THERMAL BLOCKS

8.0 STANDARD PARTS

<p>ROOF FASTENER (for panel edge attachment)</p> <ul style="list-style-type: none"> • #12 - 14 x 1 1/4" hex head, Self Drilling Screw, TEK2 • EPDM Sealing Washer • Corrosion resistant coating or alloy head • Painted or mill finished head • Long Life  <p>FM3</p>	<p>CLIP FASTENER (for panel clip attachments to wood decking)</p> <ul style="list-style-type: none"> • #10 - 12 x 1" (#2 Phillips), Phillips drive, Pan Head Screw, Type A • Corrosion resistant coating  <p>FM8</p>
<p>ROOF FASTENER (for panel edge attachment)</p> <ul style="list-style-type: none"> • #12 - 14 x 1 1/2" hex head, Self Drilling Screw, TEK2 • EPDM Sealing Washer • Corrosion resistant coating or alloy head • Painted or mill finished head • Long Life  <p>FM3A</p>	<p>BLIND RIVET (for flashing joints)</p> <ul style="list-style-type: none"> • Stainless steel • 1/8" dia. x 3/16" length  <p>FM16</p>
<p>LAP FASTENER (for flashing attachment)</p> <ul style="list-style-type: none"> • 1/4" - 14 x 7/8" Self Drilling Screw • EPDM Sealing Washer • Corrosion resistant coating or alloy head • Painted or mill finish head • Long Life  <p>FM4</p>	<p>CLIP FASTENER (for panel clip to purlins, eave plate to eave strut)</p> <ul style="list-style-type: none"> • 1/4" - 14 x 1" hex head, #2 Point Self Drilling Screw • Corrosion resistant plating • Up to 3" insulation • 5/16 Head  <p>FM50</p>
<p>PLATE FASTENER (for Hip & Valley support plates to purlins)</p> <ul style="list-style-type: none"> • #10-16 x 1", (#2 Phillips) SD3 • Corrosion resistant coating   <p>FM7</p>	<p>CLIP FASTENER (for panel clip to purlins, eave plate to eave strut)</p> <ul style="list-style-type: none"> • 1/4" - 14 x 1 1/2" hex head, #2 Point Self Drilling Screw • Corrosion resistant plating • Over 3" to 6" insulation • 5/16 Head  <p>FM51</p>

8.7 FASTENERS

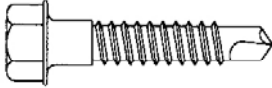
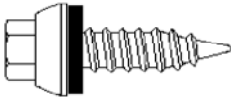
8.0 STANDARD PARTS

<p>SHOULDER FASTENER (for floating rake plate attachment to steel purlins)</p> <ul style="list-style-type: none"> • 1/4" - 14 x 1 1/4" hex head, Self Drilling Screw, TEK3, Shoulder • Shoulder feature • Corrosion resistant plating • 5/16 Head  <p>FM52</p>	
<p>ENDLAP FASTENER (for panel endlap attachment)</p> <ul style="list-style-type: none"> • #17 - 14 x 1" Self Tapping Screw, Type AB • EPDM Sealing Washer • Corrosion resistant coating or alloy head • Painted or mill finished head • Long Life • 5/16 Head  <p>FM53A</p>	
<p>CLIP FASTENER (for panel clip attachments to metal decking)</p> <ul style="list-style-type: none"> • 14 x 1 5/8" Deck Screw, #3 Phillips Truss Head • Corrosion resistant plating  <p>FM54</p>	

8.7 FASTENERS



9.0 ROOF INSTALLATION DETAILS

9.1 GENERAL

The following details provide graphic illustration of the roof assembly steps. The purpose is to instruct the erection crew in correct and efficient assembly of the roof system.

Because of the many variations in conditions, it is important that you review the job to identify and isolate the specific installation details required for your job.

Review the erection drawings for differences with these details. If differences exist, the erection drawings have precedence.

These details are arranged in a step-by-step sequence. Following this sequence ensures correct assembly and ensures that the part to be worked on will be readily accessible for the next assembly step

Do not shortcut these assembly steps without careful consideration of the possibility of incorrect or omitted assembly and the resulting corrective rework.

To minimize confusion, the details are always oriented so that the view is from eave to ridge, with the starting rake at the left and finish rake at the right. Refer to the erection drawings to determine the required sheeting direction and rake conditions.

To help ensure weathertightness, the details emphasize proper fit-up, sealing and fastening. It is most important that only the specified sealants and fasteners be used for each condition and that they be installed correctly as shown on these details and the erection drawings.

Be sure that these critical instructions are reviewed often and the roof assembly is checked at each assembly step.

This Panel is not intended for use on curved, tapered or conical shaped roofs.

ROOF INSTALLATION DETAILS