



Manufactured By



LOW PROFILE RIDGE VENTILATOR

Metallic Products' low profile ridge vents are aesthetically pleasing and an extremely efficient means of ventilating metal roofs. Each unit is manufactured in 10' lengths and can be installed as a single unit or butted together to form a continuous run. (End caps and splice kits shipped loose for field installation.) In continuous run applications, the splice kits provide the appearance of a single unit.



TDI APPROVED

ALSO AVAILABLE



Metallic Products' low profile ridge ventilators are also available in Florida Product Approved and Miami-Dade HVHZ Approved specifications.

SPECIFICATIONS

STANDARD SIZE

Each 10' unit features 180 square inches of free area with a base rating of 450 CFM of air movement. Units in lengths less than 10' can be manufactured upon request. Throat size is determined by roof pitch

DESIGN

Aerodynamic, low-profile design enhances the look and performance of architectural roof systems. The unit moves toward the ridge on floating roofs. Vents are made to match roof slope to maintain low-profile appearance.

CONSTRUCTION

Unit is factory assembled and ready for installation. Vent features the Cor-A-Vent[®], a time-tested, economical, self-cleaning and durable ventilation core. All steel parts are 24-gauge.

FINISH

Galvalume or Polar White finish is standard, and other colors are available, including Kynar[®]

NOTE

Please specify flat or die formed skirts, roof pitch and color when ordering.





TECHNICAL SPECIFICATIONS

Manufactured By

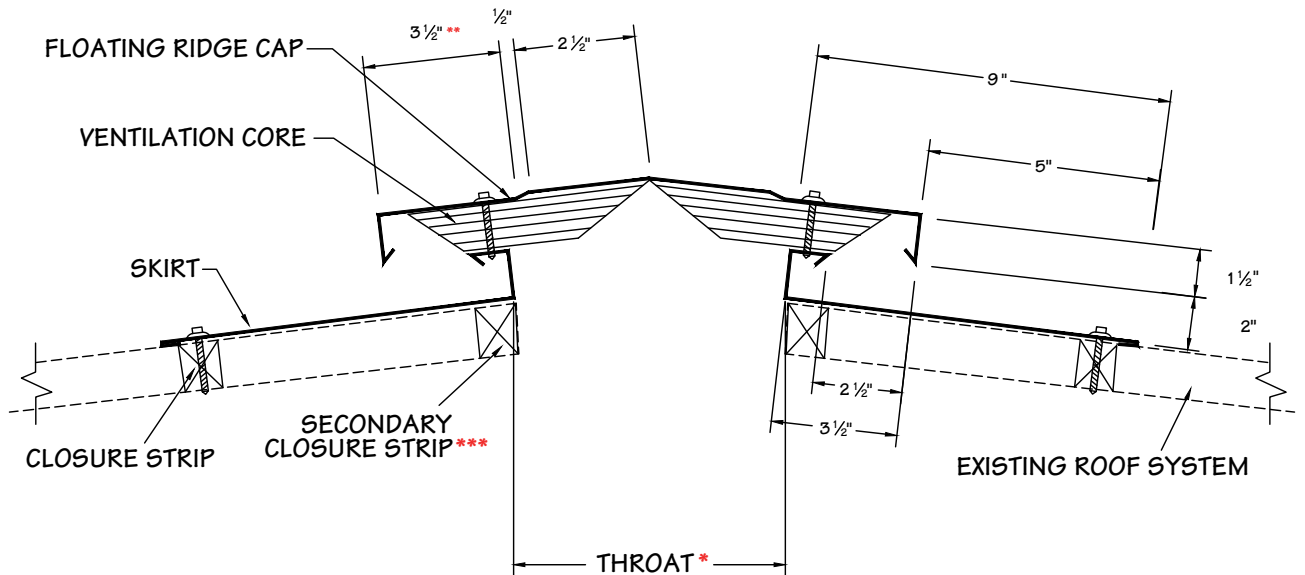

THROAT SIZE

(Determined by Roof Pitch)

PITCH	THROAT SIZE
1:12	4-1/8"
2:12	4-1/8"
3:12	4-1/8"
4:12	4-1/8"
5:12	3-1/2"
6:12	2-7/8"
7:12	4-5/8"
8:12	4-1/8"
9:12	3-1/2"
10:12	3"
11:12	2-9/16"
12:12	2"

NOTE

Roof panel must extend to throat of vent for proper support and drainage. End caps and splice kits (if necessary) are shipped loose for field installation.

* Throat varies with roof slope. (See table)

** This dimension changes to 5" on roof slopes 7:12 – 12:12.

*** Secondary closure at ridge is recommended at each skirt splice in a continuous run.





Manufactured By



TECHNICAL SPECIFICATIONS

TABLE A

Air Movement Per Lineal Foot Factors

HEIGHT (ft.)	TEMPERATURE DIFFERENCE					
	5°	10°	15°	20°	25°	30°
10'	16.65 _A	22.05 _A	26.10 _A	28.80 _A	31.50 _A	34.20 _A
15'	18.90 _A	27.00 _A	31.95 _A	36.00 _A	38.70 _A	41.40 _A
20'	23.85 _A	31.50 _A	36.45 _A	41.40 _A	44.50 _B	48.15 _B
25'	26.10 _A	34.65 _A	40.05 _A	45.00 _B	48.60 _B	53.10 _C
30'	28.35 _A	37.35 _A	43.65 _B	48.60 _B	52.65 _C	57.60 _C
35'	29.70 _A	39.15 _B	45.90 _B	51.30 _B	55.80 _C	60.75 _C
40'	31.50 _B	41.85 _B	48.60 _B	54.90 _C	58.50 _C	63.45 _C
45'	33.30 _B	43.20 _B	50.40 _B	57.60 _C	62.10 _C	66.60 _C
50'	34.65 _B	45.45 _B	53.10 _C	59.85 _C	64.80 _C	70.20 _D

TABLE B

Wind Velocity Factors

WIND (mph)	FACTORS			
	A	B	C	D
3	1.14	1.09	1.05	1.02
5	1.25	1.18	1.13	1.09
7	1.41	1.29	1.22	1.16
9	1.62	1.43	1.33	1.25
11	1.82	1.57	1.43	1.32

TOTAL CFM= (Table A) x (Table B) x Length

